

The rechargeable batteries are lead-lead dioxide systems. The dilute sulfuric acid electrolyte is absorbed by separators and plates and thus immobilized. Should the battery be accidentally overcharged producing hydrogen and oxygen, special oneway valves allow the gases to escape thus avoiding excessive pressure build-up. Otherwise, the battery is completely sealed and is, therefore, maintenance-free, leak proof and usable in any position.



Battery Construction

Component	Positive plate	Negative plate	Container	Cover	Safety valve	Terminal	Separator	Electrolyte
Raw material	Lead dioxide	Lead	ABS	ABS	Rubber	Copper	Fiberglass	Sulfuric acid

General Feature

- Absorbent Glass Mat(AGM) technology for efficient gas recombination of up to 99% and freedom from electrolyte maintenance or water adding.
- Not restricted for air transport-complies with IATA/ICAO Special Provision A67.
- UL-recognized component.
- Can be mounted in any orientation.
- Computer designed lead, calcium tin alloy grid for high power density.
- Long service life, float or cyclic applications.
- Maintenance-free operation.
- Low self discharge.

Performance Characteristics

Capacity 77°F(25°C)	10 hour rate (30A、1.8V)	300Ah
	5 hour rate (54A、1.75V)	270Ah
	3 hour rate (83A、1.70V)	249Ah
	1 hour rate (190A、1.60V)	190Ah
Internal Resistance	Full charged Battery77°F(25°C): 1mΩ	
Capacity affected by Temperature (10 hour rate)	104° F(40°C)	102%
	77° F(25°C)	100%
	32° F(10°C)	85%
	5° F(-15°C)	65%
Self-Discharge 68°F(20°C)	Capacity after 3 month storage	90%
	Capacity after 6 month storage	80%
	Capacity after 12month storage	60%
Max. discharge current77°F(25°C): 1500A(5S)		
Charge (Constant Voltage)	Float: 2.25~2.30 V/77° F(25°C)	
	Cycle:2.35~2.45 V/77°F(25°C) Max. Current: 60A	

SPECIFICATION

Nominal voltage 2V
 Number of cell 1
 Length(mm/inch) 171/6.73
 Width(mm/inch) 151/5.94
 Height(mm/inch) 330/13.0
 Total Height(mm/inch) 364/14.3
 Approx. Weight(kg/lbs) 18.5/40.8

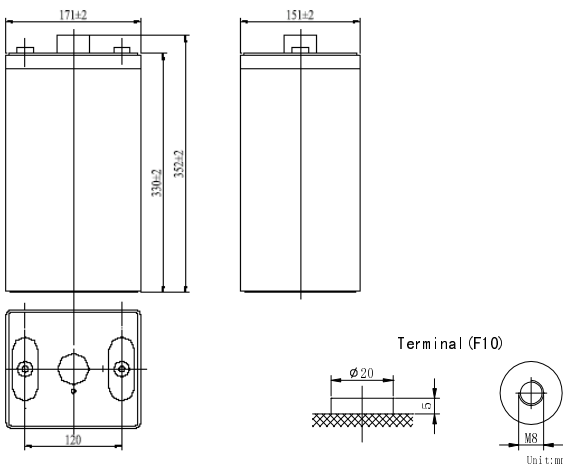

Total height with removable cover:364

Discharge Constant Current (Amperes at 77° F25 °C)

End Point Volts/Cell	5min	10min	15min	30min	45min	1h	3h	5h	10h
1.60V		493	443	300	240	190	89.0	58.3	32.1
1.65V		467	422	290	230	184	86.5	57.1	31.8
1.70V		440	400	281	220	178	83.0	55.6	31.3
1.75V		413	378	272	210	171	80.0	54.0	30.7
1.80V		385	355	260	199	163	76.0	52.0	30.0

Discharge Constant Power (watts at 77° F 25 °C)

End Point Volts/Cell	5min	10min	15min	30min	45min	1h	2h	3h	5h
1.60V		887	795	608	476	385	247	175	115
1.65V		835	756	581	460	371	241	171	113
1.70V		783	718	554	443	357	234	166	111
1.75V		732	679	527	427	342	228	162	108
1.80V		680	640	500	410	328	221	157	105

(Note)The above characteristics data are average values obtained Within three charge/discharge cycles not the minimum values.

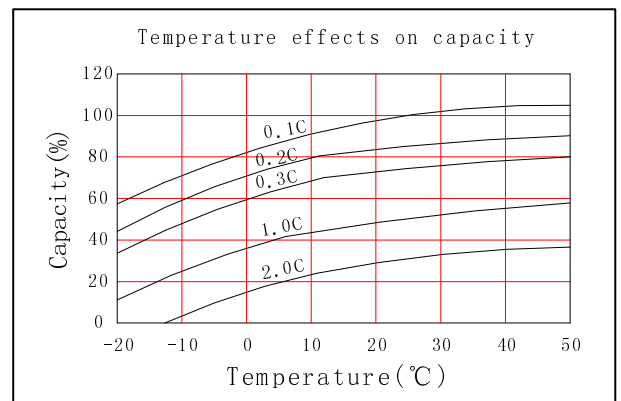
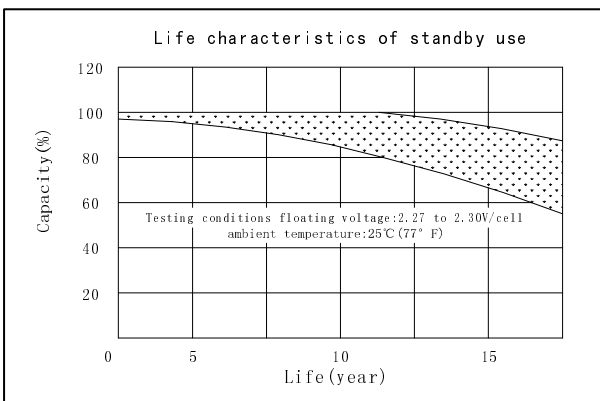
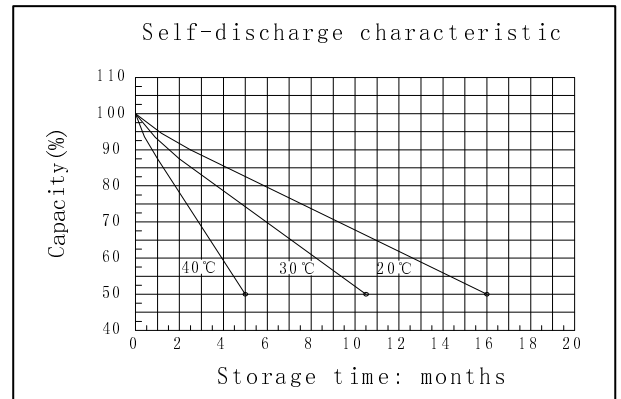
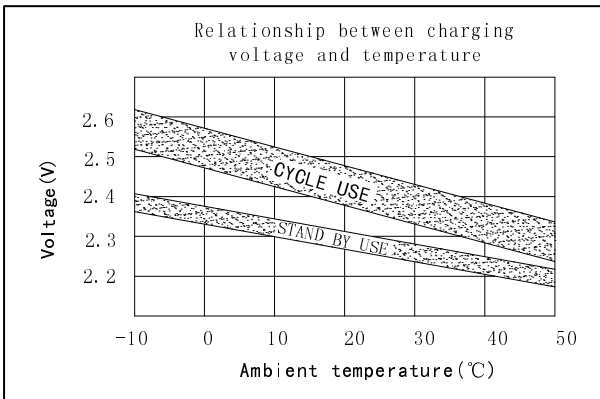
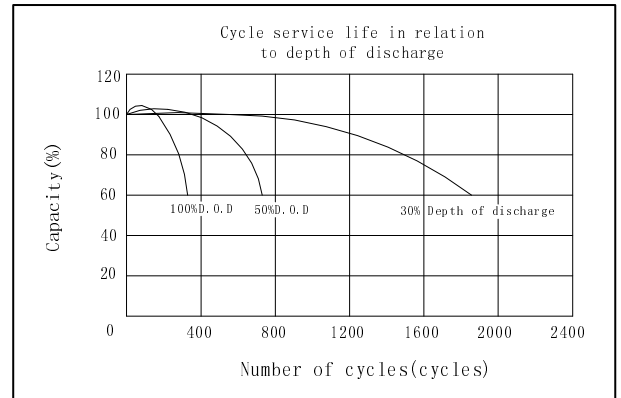
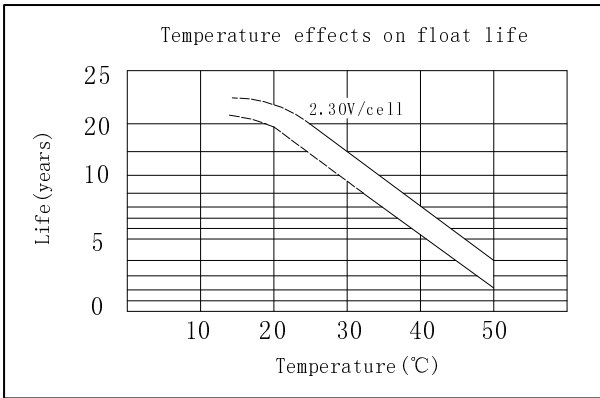
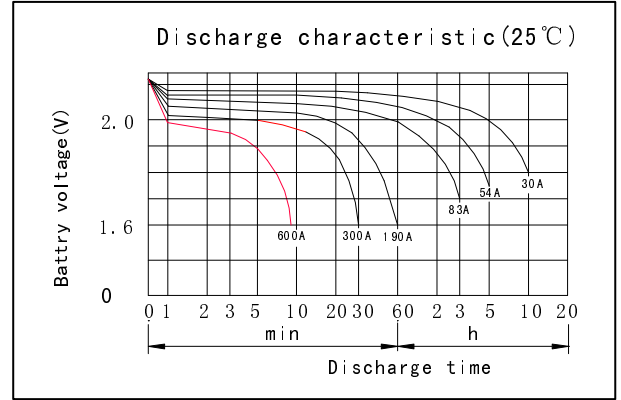
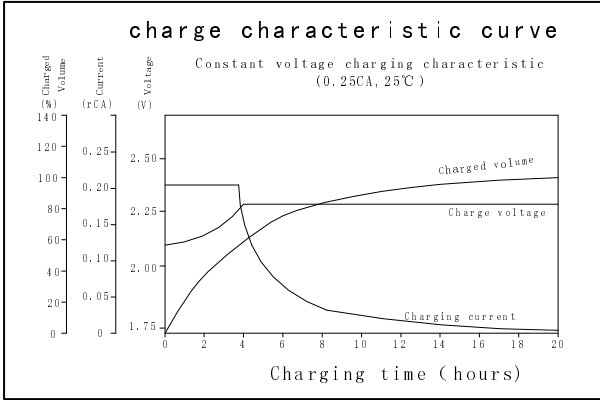

GREAT POWER BATTERY TECHNOLOGY CO.,LTD

Address: Longguan 1st Road, LongHua Town, BaoAn District, Shenzhen, China.

TEL: 86-755-2900 8403 Fax: 86-755-3386 3366

Email: info@greatpowerbattery.com Http:// www.greatpowerbattery.com